

CURVED, ISOPARAMETRIC, "QUADRILATERAL" ELEMENTS FOR FINITE ELEMENT ANALYSIS

I. ERGATOUDIS, B. M. IRONS and O. C. ZIENKIEWICZ

Civil Engineering Division, University of Wales, Swansea

Abstract—An increase of available parameters associated with an element usually leads to improved accuracy of solution for a given number of parameters representing the whole assembly. It is possible thus to use fewer elements for the solution.

As such element have yet to be able to follow prescribed boundaries to a good degree of approximation curved shapes are desirable.

The paper describes the theory of a new "family" of "isoparametric" elements for use in two-dimensional situations. Examples illustrating the accuracy improvement are included.

1. INTRODUCTION

WITH the firm establishment of the principles of finite element analysis, it is found that the development of element characteristics will follow a prescribed path once the shape functions have been chosen. For instance in the analysis of plane stress or strain once the functions describing the displacements within the element in terms of the nodal values are known, standard expressions can be used and the element properties are uniquely defined. The possibilities of improvement of approximation are thus confined to devising alternative element configurations and developing new shape functions.

In two-dimensional analysis the simplest element shapes are obviously a triangle and a rectangle, defined by three or four nodes respectively. The first has rightly become most popular due to the ease with which the subdivision can be graded and boundary shapes approximated. The rectangular shape places much greater constraints on these factors and has a very limited applicability. Both elements present the lowest possible forms of approximation and are of limited accuracy.

An obvious improvement is the addition of a number of nodal points along the sides of such elements thus permitting a smaller number of variables to be used for solution of practical problems with a given degree of accuracy. Unfortunately the number of elements required is often governed by the need to represent boundary configurations reasonably. Here, with a smaller number of more complicated elements, the straight sides of the elements mentioned are a distinct drawback. This paper is therefore concerned with a method of generating a series of elements which may, if desired, be given curved sides.

The basic shape of the element chosen is a quadrilateral, the sides of which can, however, be distorted in a prescribed way. It will be found that if only the corner nodes are involved the sides will still be straight and will lead to the Taig [1] type of formulation. With one additional point involved in each side a parabolic shape becomes possible while with two points a cubic is included. The general shape of the element will be described, for lack of a better name, as the isoparametric quadrilateral [2].

2. CO-ORDINATE DEFINITION

Consider two co-ordinates η - ξ to be associated with each of the "quadrilaterals" of Fig. 1. These co-ordinates which in general are curvilinear will be so determined as to give

$$\eta = -1 \text{ on side } 12$$

$$\eta = +1 \text{ on side } 43$$

$$\xi = 1 \text{ on side } 23$$

$$\xi = -1 \text{ on side } 14$$

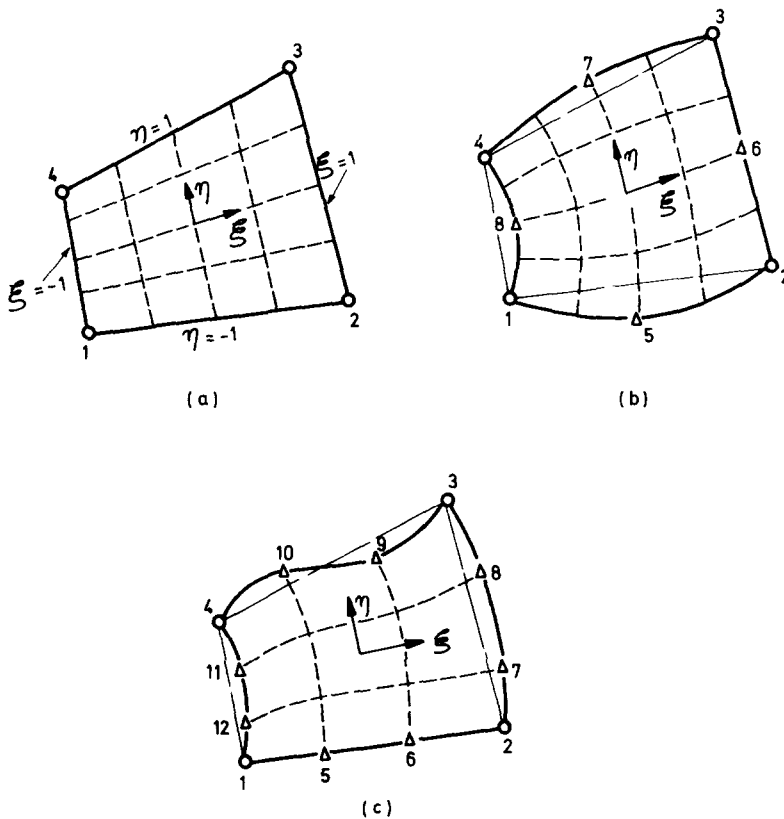

FIG. 1. General "quadrilateral" elements with nodes placed along straight lines all reduce to shape (a).

The relationship between the Cartesian co-ordinates and the new co-ordinates must now be established. This in a general form will be written as

$$\begin{aligned} x &= N_1 x_1 + N_2 x_2 + N_3 x_3 + \dots = \{N\}^T \{x_n\} \\ y &= N_2 y_1 + N_2 y_2 + N_3 y_3 + \dots = \{N\}^T \{y_n\} \end{aligned} \quad (1)$$

in which $\{x_n\}$ and $\{y_n\}$ lists the nodal co-ordinates x and y and N_1, N_2 , etc. are some, as yet undetermined, functions of η and ξ . For any values of ξ and η the x and y co-ordinates can be found once the functions N are known. The sides of each element are defined as both x and y co-ordinates are given parametrically in terms of either ξ and η and can obviously be curved.

One important point arises here. As adjacent elements have to fit each other, their sides will have to be uniquely determined by the common points. Thus, for example, along a side 12 the co-ordinates x and y will be defined parametrically in terms of ξ as linear, quadratic and cubic functions respectively in elements of type (a), (b) and (c) of Fig. 1. The simplest element will thus have straight sides while the others will be curved if the points defining them do not lie on a straight line.

Before defining the specific form of the functions " N " we shall turn to the definition of shape or displacement functions required for the finite element.

Contours of typical ξ and η co-ordinates as shown in Fig. 1 indicate the patterns.

3. ISOPARAMETRIC SHAPE FUNCTIONS

In finite element analysis it will be necessary to define the variation of displacement components u and v (or indeed if extended application to field problems is considered of other functions such as temperature, potentials, etc.) in terms of the nodal values of these functions. Suitable shape functions are generally written in terms of Cartesian co-ordinates. Now we shall use the new co-ordinates and also assume that the same functions N_1, N_2 , etc. previously used can be again employed. Such shape functions will be termed isoparametric. Thus we have

$$\begin{aligned} u(\xi, \eta) &= N_1 u_1 + N_2 u_2 + \dots = \{N\}^T \{u_n\} \\ v(\xi, \eta) &= N_1 v_1 + N_2 v_2 + \dots = \{N\}^T \{v_n\} \end{aligned} \quad (2)$$

in which N_1 etc. are functions of ξ, η and u_1, v_1 etc. represent the nodal values of displacements.

4. SATISFACTION OF CONVERGENCE CRITERIA

So far no restriction has been placed on the shape functions N chosen apart from the implication that

$$N_1 = 1 \text{ at node 1 and zero at all the other nodes with a similar requirement for all other functions.}$$

Now it is necessary to make sure that the functions satisfy the two criteria* necessary for convergence of the finite element analysis [3, 4]. The first is that any required state of constant strain can be adequately reproduced on an element. (For field problems we should modify "displacement" to temperature, potential etc. and "strain" to first derivatives of these quantities). The second is that the displacement be continuous between adjacent elements.

* The third criterion regarding the capability of representing "rigid body" type of movement is implicit in the "constant strain" criterion and need not be specified separately.

With regard to the first condition it will be shown that *isoparametric shape functions automatically ensure that any constant strain is available*. For any constant strain

$$u = a + bx + cy \quad (3)$$

where a, b and c are arbitrary constants (with similar requirement for v). Thus

$$\begin{aligned} u &= a + bx + cy = N_1 u_1 + N_2 u_2 + \dots \\ &= N_1(a + bx_1 + cy_1) + N_2(a + bx_2 + cy_2) + \dots \\ &= a(N_1 + N_2 + \dots) + b(N_1 x_1 + N_2 x_2 + \dots) + \\ &\quad + c(N_1 y_1 + N_2 y_2 + \dots) \end{aligned} \quad (4)$$

which is an identity by virtue of the definition of the co-ordinates x and y (equation 1) and if

$$N_1 + N_2 + N_3 + \dots = 1 \quad (5)$$

This last statement must be true as the co-ordinates have to be defined uniquely for any nodal values. Thus, for example, the element size decreases to zero and $x_1 \rightarrow x_2 \rightarrow x_3$ etc. $\rightarrow A$. Thus also for any internal point $x \rightarrow A$ and substituting we have

$$A = N_1 A + N_2 A + \dots \quad (6)$$

which verifies the previous assertion.

To satisfy the continuity of displacement along the interfaces it is necessary for u and v to be uniquely defined along the quadrilateral edges such as 12 by the displacements of the nodes associated with that edge. This is possible only if the displacements vary linearly, quadratically or cubically for elements of type (a), (b) or (c) shown in Fig. 1. This condition has already been implied when fit of elements before deformation was considered.

5. GENERATION OF POLYNOMIAL SHAPE FUNCTIONS

Suitable polynomials for the various elements which satisfy the necessary condition of continuity can be written by including only terms which give the appropriate variation along sides of the element.

Linear element (Fig. 1a)

For element of Fig. 1a we can write for instance

$$x = \alpha_1 + \alpha_2 \xi + \alpha_3 \eta + \alpha_4 \xi \eta = [1, \xi, \eta, \xi \eta] \{\alpha_n\} \quad (7)$$

which ensures that on the sides $\eta = \pm 1$ variation is linear with ξ and correspondingly when $\xi = \pm 1$ is linear with η .

Substituting the nodal values

$$\begin{aligned} x = x_1 & \quad \xi = \eta = -1 \\ x = x_2 & \quad \xi = 1, \eta = -1 \\ x = x_3 & \quad \xi = \eta = 1 \\ x = x_4 & \quad \xi = -1, \eta = 1 \end{aligned} \quad (8)$$

yields four equations of type

$$\{x_n\} = [C]\{\alpha_n\} \quad (9)$$

from which

$$\{\alpha_n\} = [C]^{-1}\{x_n\} \quad (10)$$

and the shape functions follow as

$$[N_1, N_2, N_3, N_4] = [1, \xi, \eta, \xi\eta][C]^{-1} \quad (11)$$

It is nevertheless possible to use a more direct approach and write by inspection

$$N_1 = \frac{1}{4}(1 - \xi)(1 - \eta)$$

$$N_2 = \frac{1}{4}(1 + \xi)(1 - \eta)$$

$$N_3 = \frac{1}{4}(1 + \xi)(1 + \eta)$$

$$N_4 = \frac{1}{4}(1 - \xi)(1 + \eta)$$

or generally

$$N_i = \frac{1}{4}(1 + \xi\xi_i)(1 + \eta\eta_i) \quad (12)$$

where ξ_i and η_i take their nodal values.

Quadratic element (Fig. 1b)

Now again one can postulate an expansion of the form

$$x = \alpha_1 + \alpha_2\xi + \alpha_3\eta + \alpha_4\eta\xi + \alpha_5\xi^2 + \alpha_6\eta^2 + \alpha_7\xi^2\eta + \alpha_8\xi\eta^2 \quad (13)$$

and substitute the appropriate nodal values

$$x = x_1 \quad \eta = -1 \quad \xi = 1$$

$$x = x_5 \quad \eta = 0 \quad \xi = 1$$

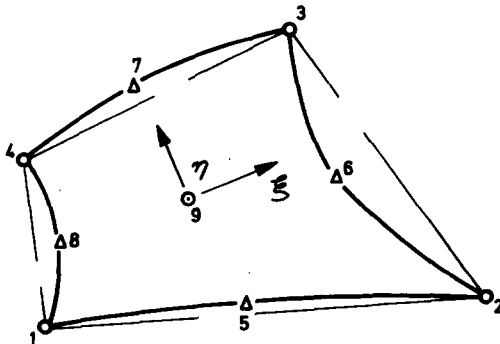

FIG. 2. "Quadrilateral" element of Fig. 1b with an additional internal node at co-ordinate origin.

and hence obtain the shape functions as

$$[N_1, N_2, N_3 \dots] = [1, \xi, \eta, \xi\eta, \xi^2, \eta^2, \eta^2\xi, \eta\xi^2][C]^{-1} \quad (14)$$

Alternatively the explicit form can be written directly. (Appendix, see also [5].)

This obviously is not the only function possible. Any number of additional internal nodes could, for instance, be added and the number of terms increased appropriately as long as quadratic variation along the sides is maintained. Figure 2 shows a "quadratic" element with one internal node, and here the extra term to add would be $\eta^2\xi^2$. The explicit shape functions are given in Appendix [5].

Cubic element (Fig. 1c)

Now the obvious expansion will be

$$x = \alpha_1 + \alpha_2\xi + \alpha_3\eta + \alpha_4\xi\eta + \alpha_5\eta^2 + \alpha_6\xi^2 + \alpha_7\xi^3 + \alpha_8\xi^2\eta + \alpha_9\xi\eta^2 + \alpha_{10}\eta^3 + \alpha_{11}\eta^3\xi + \alpha_{12}\eta\xi^3 \quad (15)$$

Once again the same process can be used. Explicit shape functions are given in Appendix.

6. ELASTIC ELEMENT PROPERTIES

In the standard formulation of plane stress or strain the stiffness matrix is given by

$$[k] = \iint [B]^T [D] [B] dx dy \quad (16)$$

in which $[B]$ is the matrix defining the strains in terms of the nodal displacements and $[D]$ is the elasticity matrix which relates the stresses to the strains. The strain matrix is given by

$$\{e\} = \begin{Bmatrix} \frac{\partial u}{\partial x} \\ \frac{\partial v}{\partial y} \\ \frac{\partial u}{\partial y} + \frac{\partial v}{\partial x} \end{Bmatrix} = [B] \begin{Bmatrix} u_1 \\ v_1 \\ u_2 \\ v_2 \\ \vdots \\ \vdots \end{Bmatrix} \quad (17)$$

in which

$$[B] = [B_1, B_2, \dots] \quad (18)$$

with

$$B_i = \begin{bmatrix} \frac{\partial N_i}{\partial x} & 0 \\ 0 & \frac{\partial N_i}{\partial y} \\ \frac{\partial N_i}{\partial y} & \frac{\partial N_i}{\partial x} \end{bmatrix} \quad (19)$$

As N_i is defined in terms of ξ and η it is necessary to change the derivatives to $\partial/\partial x$ and $\partial/\partial y$. Noting that

$$\begin{Bmatrix} \frac{\partial N_i}{\partial \xi} \\ \frac{\partial N_i}{\partial \eta} \end{Bmatrix} = \begin{bmatrix} \frac{\partial x}{\partial \xi} & \frac{\partial y}{\partial \xi} \\ \frac{\partial x}{\partial \eta} & \frac{\partial y}{\partial \eta} \end{bmatrix} \begin{Bmatrix} \frac{\partial N_i}{\partial x} \\ \frac{\partial N_i}{\partial y} \end{Bmatrix} = [J] \begin{Bmatrix} \frac{\partial N_i}{\partial x} \\ \frac{\partial N_i}{\partial y} \end{Bmatrix} \quad (20)$$

in which $[J]$ is the Jacobian matrix which can easily be evaluated by a numerical process [3], noting that

$$[J] = \begin{bmatrix} \frac{\partial N_1}{\partial \xi} & \frac{\partial N_2}{\partial \xi} & \dots \\ \frac{\partial N_1}{\partial \eta} & \frac{\partial N_2}{\partial \eta} & \dots \end{bmatrix} \begin{bmatrix} x_1 & y_1 \\ x_2 & y_2 \\ \vdots & \vdots \end{bmatrix} \quad (21)$$

we can write

$$\begin{aligned} \frac{\partial N_i}{\partial x} &= [1, 0][J]^{-1} \begin{Bmatrix} \frac{\partial N_i}{\partial \xi} \\ \frac{\partial N_i}{\partial \eta} \end{Bmatrix} \\ \frac{\partial N_i}{\partial y} &= [0, 1][J]^{-1} \begin{Bmatrix} \frac{\partial N_i}{\partial \xi} \\ \frac{\partial N_i}{\partial \eta} \end{Bmatrix} \end{aligned} \quad (22)$$

and thus calculate the expression for $[B_i]$.

The only further change which requires to be done is to replace the element of area as

$$dx dy = \det [J] d\eta d\xi$$

and the limits of integration to -1 and 1 in both integrals.

Actual integration will in general have to be performed numerically using, for example, Legendre–Gauss points [6].

Description of some of the details of numerical integration is given in Refs. [2–4]. Clearly load, mass, stress and other matrices will be derived in an analogous manner.

For problems with axial symmetry a different definition of strains and appropriate element of volume is the only change required.

7. EXAMPLE AND CONCLUDING REMARKS

Only one example is quoted here. In this a problem of a cylindrical ring subject to a line load is solved using the 4 and 8 nodal quadrilaterals, Fig. 3. Both show a considerable improvement in accuracy over simpler "constant strain" element solutions as indeed is to

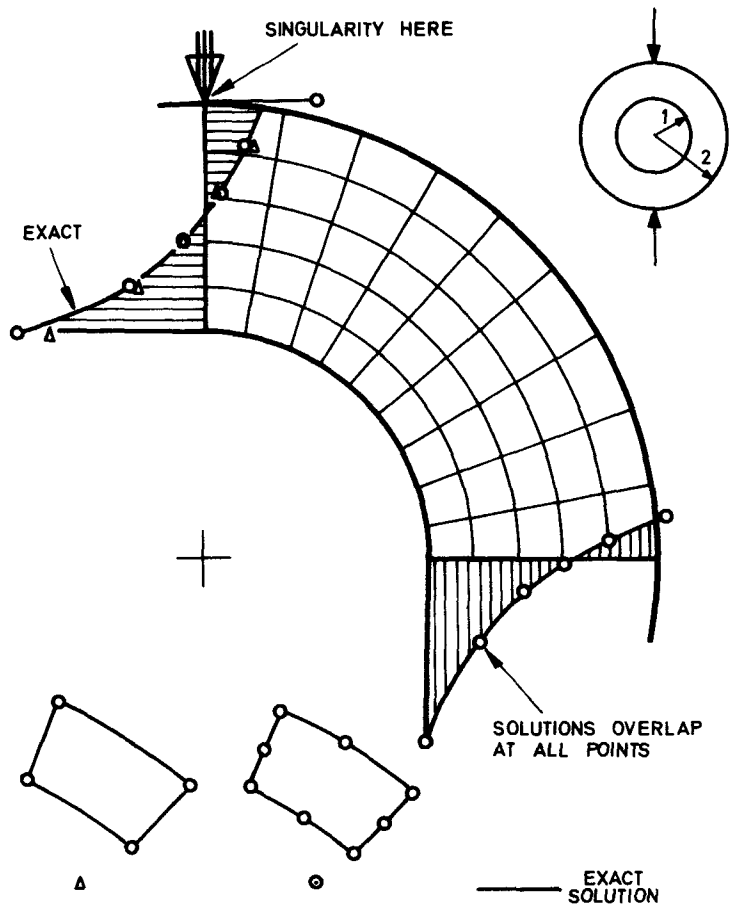

FIG. 3 (a). A cylinder under two concentrated loads. Plot of hoop stresses for two solutions with different quadrilateral elements.

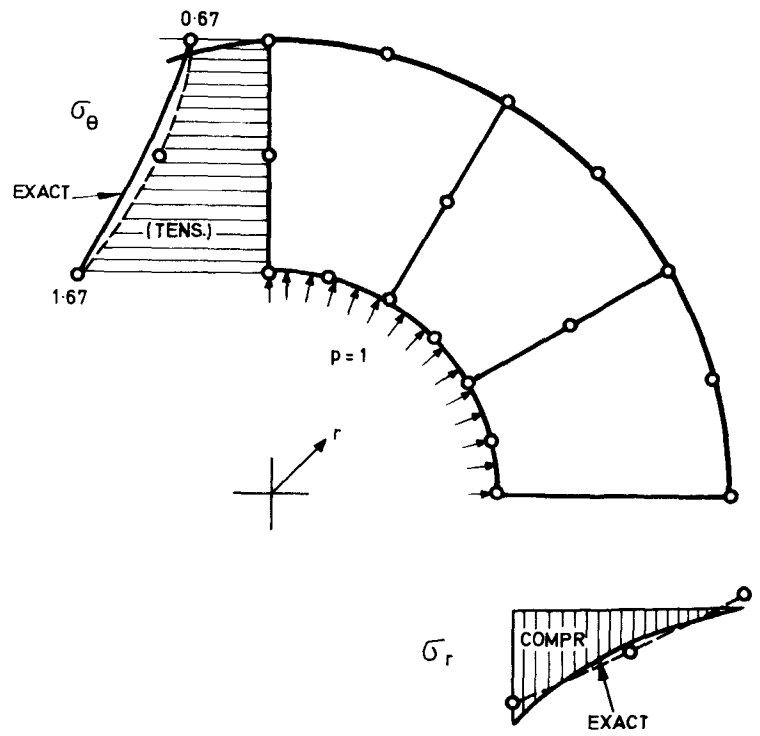
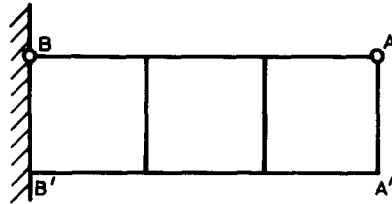

FIG. 3 (b). Cylinder of Fig. 3(a) but now with unit internal pressure. Single layer of large elements of type 1b.

be expected. Beam flexure problems can be represented very closely using one element in the thickness of a beam (Fig. 4). This, as is well-known, is impracticable with simple triangular elements.







TYPE OF ELEMENT	VERTICAL LOAD OF A		COUPLE AT A A'	
	MAX DEFL AT AA'	MAX STRESS BB'	MAX DEFL AT AA'	MAX STRESS BB'
	.26	.19	.22	.22
	.65	.56	.67	.67
	.99	.99	1.00	1.00
	1.00	1.00	1.00	1.00
EXACT	1.00	1.00	1.00	1.00

FIG. 4. Four elements used to represent a cantilever. Improvement of accuracy with element order is evident.

With programs of this type an opportunity arises for a simplification of input—a serious practical problem where a large number of elements is involved. As the accuracy is improved a reduced number of elements in itself reduces the possibility of errors. For intermediate nodes (along sides of quadrilaterals) it is not necessary to specify the co-ordinates if such sides are to be straight. The program is efficiently arranged. Such co-ordinates will be available from interpolation. Only when the particular side requires to follow a curved boundary is it necessary to specify all intermediate points.

Further experience is still desirable to ascertain what distortion of element sides is possible without introducing inaccuracies due to violent shape functions. Convergence is nevertheless assured with all possible shapes.

Numerical integration processes involve little programming, and such unfamiliar routines as are needed tend to be generally applicable. With care they can use remarkably little computer storage, and the penalty in computer time can be reduced to the point where

the more efficient use of nodes gives a great improvement. But it is the less spectacular advantages that make the consistent use of numerical integration so attractive in the long term. Instead of accumulating a library of stiffness matrices, one accumulates a library of shape function routines, each of which is the raw material not for one matrix but for many, e.g. mass matrices, axisymmetric problems, field problems, various types of distributed load, etc. One can check a "shape function" routine in itself, decisively and with a small computer: for example, one can check nodal values, and the computer can check derivatives by finite differences, so that the routine can confidently be put into "cold storage" until it is needed. Indeed, the chances of mistakes in programming are greatly reduced, as is the programming gap between a new idea and its implementation. For example, an element with 96 degrees of freedom, recently used in three-dimensional analysis, was written and tested on a medium size (ICT 1905) computer in under a week, using an existing shape function routine.

Experience with these important little routines shows that by writing many element configurations into one routine one gains an even greater concentration of technical power. For example, a quadrilateral can have cubic response along side 34, which contains four nodes, linear response along side 12, which now contains only the corner nodes, and quadratic along the other two (Fig. 5). Also, any pair of corners may coalesce to give a triangle. With a routine that calculates any such combination, the engineer is enabled to mix his elements, using refined elements in regions where he expects rapid stress variation.

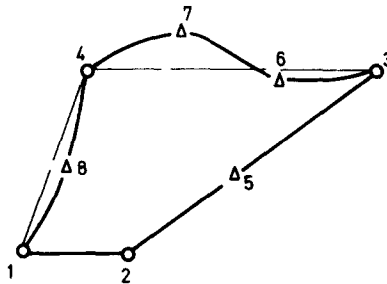

FIG. 5. Possible element of "mixed" type. Two, one or no mid-side nodes.

The processes described here are easily extended to three-dimensional analysis with a basic, eight cornered element. Experience has shown that for such situations the accuracy gained with the use of complex elements is of great economic advantage.

It is finally interesting to remark that the process of finite element analysis being simply a piecewise Ritz approximation is seen to converge by use of more and more complex elements towards the more conventional approximations used.

These represent in effect "one element" solution. The circle thus becomes complete.

REFERENCES

- [1] I. C. TAIG, Structural analysis by the matrix-displacement method. *Engl. elect. Aviat. Rep.* No. S017 (1961).
- [2] B. M. IRONS, Numerical integration applied to finite element methods. *Conf. Use of Digital Computers in Structural Engineering*, Univ. of Newcastle, July 1966.
- [3] B. M. IRONS, Engineering application of numerical integration in stiffness method. *AIAA Jnl* 4, 2035-2037 (1966).

- [4] O. C. ZIENKIEWICZ and Y. K. CHEUNG, *The Finite Element Method in Structural and Continuous Mechanics*. McGraw-Hill (1967).
 [5] I. ERGATOUDIS, Quadrilateral elements in plane analysis. M.Sc. thesis, University of Wales, Swansea.
 [6] A. H. STROUD and D. SECREST, *Gaussian Quadrature Formulae*. Prentice-Hall (1966).

APPENDIX

Quadratic element (Fig. 1b)

For the quadrilateral with additional midside nodes ("quadratic" element) the shape functions for a corner node are given by:

$$N_i = \frac{1}{4}(1 + \xi_0)(1 + \eta_0) - \frac{1}{4}(1 - \xi^2)(1 + \eta_0) - \frac{1}{4}(1 + \xi_0)(1 - \eta^2)$$

where $\xi_0 = \xi\xi_i$ and $\eta_0 = \eta\eta_i$, ξ_i and η_i being both ± 1 .

For a midside node the following expression gives the shape function with $\xi_i = 0$

$$N_i = \frac{1}{2}(1 - \xi^2)(1 + \eta_0)$$

and where $\eta_i = 0$

$$N_i = \frac{1}{2}(1 + \xi_0)(1 - \eta_2).$$

These formulae submit to fairly compact programming, but further simplifications follow if we redefine the midside nodal deflections as the departures from linearity. With this simple but far-reaching change we can join a quadratic element to a linear element by ignoring the inappropriate midside node. By treating the cubic similarity—that is, by introducing additional cubic terms as the deviation from quadratic behaviour at each midside—we can combine all three classes of element in the same problem. Equally important, we can write a single shape function routine to deal with all cases, and thus save storage.

Quadratic element with central node (Fig. 2)

The product functions are generated by an even simpler routine. Consider the multipliers for Lagrangian interpolation:

$$B_{n1} = -\frac{1}{2}\xi(1 - \xi)$$

$$B_0 = 1 - \xi^2$$

$$B_1 = \frac{1}{2}\xi(1 + \xi)$$

and also C_1 , C_0 and C_1 which are the same functions of η . The response from a node (ξ_i, η_i) where ξ_i and η_i are $-1, 0$ and 1 , is $N_i = B_{\xi_i} C_{\eta_i}$. Thus for example, for $\xi_i = 1, \eta_i = 0$,

$$\begin{aligned} N_i &= B_1 C_0 \\ &= \frac{1}{2}\xi(1 + \xi)(1 - \eta^2) \end{aligned}$$

and for

$$\begin{aligned} \xi_i &= 0, \quad \eta_i = -1, \\ N_i &= -\frac{1}{2}(1 - \xi^2)\eta(1 - \eta). \end{aligned}$$

Cubic element with nodes at $\frac{1}{3}, \frac{2}{3}$ along each side (Fig. 1c)

These functions again resemble those for the quadratic elements. For the corner node the shape function is:

$$N_i = \frac{1}{3^2} (1 + \xi_0)(1 + \eta_0) \{-10 + 9(\xi^2 + \eta^2)\}$$

where $\xi_0 = \xi\xi_i$ and $\eta_0 = \eta\eta_i$, and η_i being ± 1 .

For a node along the sides $\xi_i = \pm 1$, with $\eta_i = \pm \frac{1}{3}$, the shape function is:

$$N_i = \frac{9}{3^2} (1 + \xi_0)(1 - \eta^2)(1 + \eta_0)$$

and for a node along the sides $\eta_i = \pm 1$, with $\xi_i = \pm \frac{1}{3}$ the shape function is:

$$N_i = \frac{9}{3^2} (1 - \xi^2)(1 + \xi_0)(1 + \eta_0)$$

(Received 21 February 1967; revised 15 June 1967)

Абстракт—Приращение достижимых параметров, связанных с элементом, ведет обычно к улучшению точности расчета при заданном числе параметров, которые представляют целое множество. Таким образом, можно использовать меньше элементов для получения решения. Чтобы эти элементы имели возможность описывать предписанные контуры с хорошей степенью приближения, то наиболее желательным являются искривленные формы.

Работа описывает теорию нового "семейства" "изопараметрических" элементов для использования ее в двумерных задачах. Приводятся примеры, которые иллюстрируют улучшение точности расчета.